

DUETT

SHOWER & BATH

MONTAGEANLEITUNG

Duschtür und Seitenwand

ASSEMBLY INSTRUCTIONS

Shower door and sidescreen

NOTICE DE MONTAGE

Porte de douche et un panneau fixe

DUS.37

DUS.88

MA_DUBW_Duett_TürSW_11915_09_15

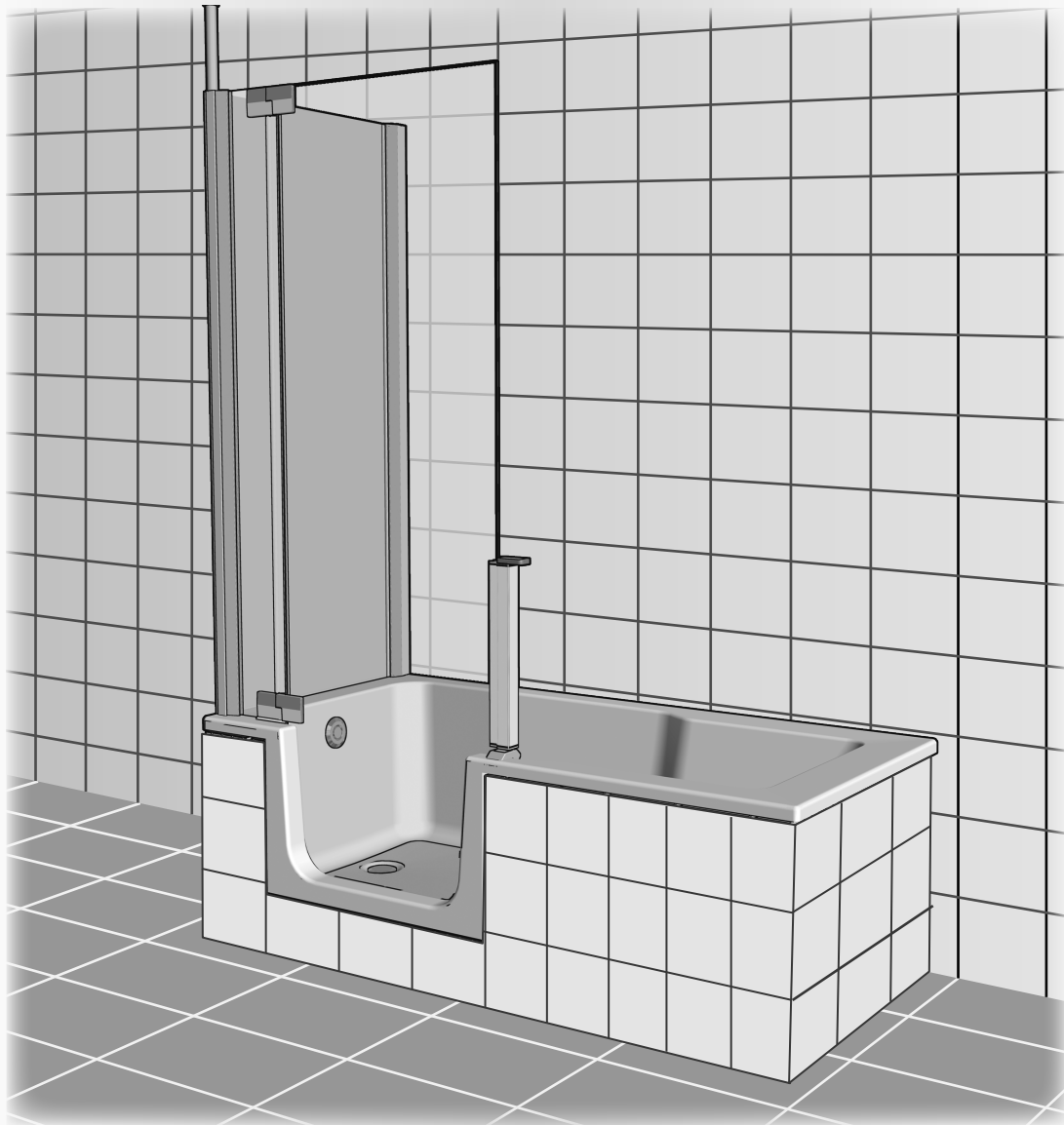

Vor Gebrauch sorgfältig lesen! Zum Nachschlagen und Aufbewahren dem Endkunden übergeben!

Read carefully before use! Hand over to the customer for looking up and storage!

Avant emploi lire soigneusement! Remettez le au client pour la recherche et le stockage!

DEUTSCH
Originalsprache

ENGLISH
Translation

FRANCAIS
Traduction

INHALTSVERZEICHNIS		OVERVIEW		VUE D'ENSEMBLE	
INHALTSVERZEICHNIS	2	OVERVIEW	2	VUE D'ENSEMBLE	2
SICHERHEITS-HINWEISE	3	SAFETY INSTRUCTIONS	3	INSTRUCTIONS SÉCURIT	3
BENÖTIGTES WERKZEUG	5	NECESSARY TOOLS	5	OUTILLAGE NECESSAIRE	5
MONTAGESET	6	ASSEMBLY KIT	6	SET DE MONTAGE	6
MONTAGE	7	ASSEMBLY	7	MONTAGE	7
» MONTAGE Seitenwand	7	» INSTALLATION OF Sidescreen	7	» MONTAGE panneau FIXE	7
» MONTAGE FIXTEIL.....	13	» INSTALLATION OF		» MONTAGE PARTIE FIXE	13
» MONTAGE TÜR.....	15	» IMMOVABLE ELEMENT	13	» MONTAGE DE LA PORTE.....	15
» MONTAGE GRIFF	16	» INSTALLATION DOOR.....	15	» MONTAGE POIGNÉE	16
» MONTAGE DICHTLEISTEN	16	» INSTALLATION OF HANDLE	16	» MONTAGE BAGUETTES D'ÉTANCHÉITÉ	16
» ABDICHTEN MIT SANITÄRSILIKON	19	» INSTALLATION OF SEALING STRIP	16	» ETANCHER AVEC DU	
		» SEALING WITH SANITARY SILICONE ...	19	» SILICONE SANITAIRE	19
ERSATZTEILE	21	SPARE PARTS	21	PIÈCES DÉTACHÉES	21



Montageanleitung für Einbau LINKS -
bei Einbau RECHTS - spiegelgleicher Aufbau.

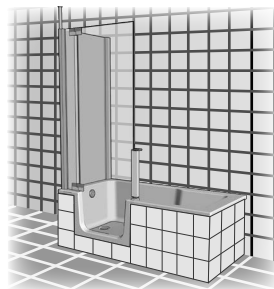

Assembly instructions for installation
LEFT -
for installation RIGHT - assemble in mirror image.

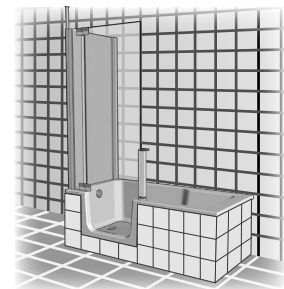

C'est prévue pour une installation à
GAUCHE -
en cas d'une installation à DROITE -A inverser pour
partie fixe en GAUCHE.

DE Vor dem Einbau bitte unbedingt beachten!

- Produkt **vor dem Einbau**, auf Richtigkeit, Beschädigungen und das Zubehör auf Vollständigkeit **überprüfen**.
- **Bei sichtbarem Schaden Produkt keinesfalls einbauen!**
- **Beachten Sie beim Hantieren das teilweise hohe Gewicht und/oder die großen Abmessungen von Einzelteilen**
- **Beachten Sie beim Bohren der Löcher, dass Sie keine Leitungen (Elektro, Gas, Wasser) beschädigen.**

Unsere Haftung beschränkt sich alleine auf unsere Produkte und kann daher nicht auf den Ein- und Ausbau ausgedehnt werden. Die Kosten für einen nachträglichen Aus- und Einbau eines Produkts und die damit verursachten Schäden sind kein Bestandteil der Garantie.

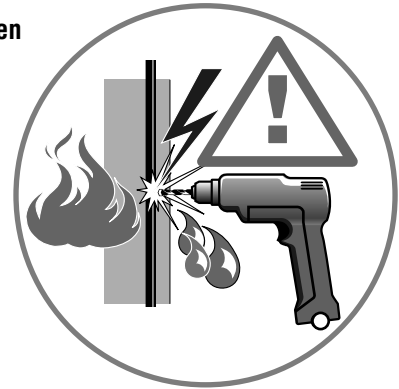

EN Please note carefully before installing

- Before installing, check for correctness and damage and the accessories for completeness.
- **Do not under any circumstances install product with visible damage!**
- **Take the great weight and/or the large dimensions into consideration when handling individual parts!**
- **When drilling holes do not damage hidden pipes and wiring.**

Our liability is limited to our products alone and therefore cannot be extended to installation and dismantling. Costs for subsequent dismantling and installation of a product and damage caused thereby are not part of the guarantee.

FR A respecter impérativement avant le montage

- Avant le montage de vérifier qu'il s'agit du bon modèle, qu'elle n'est pas endommagée et que les accessoires sont complets.
- **En cas de dommages visibles, ne pas monter le produit!**
- **Lors de la manutention, merci de prêter attention au poids parfois très élevé et/ou aux dimensions de certaines pièces!**
- **Faites attention en percant les trous de ne pas endommager les tuyauteries (cables électriques, canalisations de gaz, d'eau, etc).**

Notre responsabilité se limite à nos produits et ne peut être étendue sur l'installation et le démontage. Les coûts générés lors d'un démontage après installation et d'une ré-installation d'un produit et les dommages qui en résultent ne pourront être pris en charge par la garantie.



DE ACHTUNG!

Beim Hantieren mit Glas Schutzkleidung tragen!

Bitte untersuchen Sie nach dem Auspacken das Einscheiben-Sicherheitsglas (ESG) unverzüglich auf mögliche Transportschäden, wie abgesprungene Kanten oder Ecken. Wird ein Schaden festgestellt bitte umgehend Schadensmeldung machen und die Scheibe nicht einbauen, da dieser Fehler auch später zu einem Bruch führen kann! Alle Gläser werden vor dem Verpacken sorgfältigst kontrolliert. Spätere Reklamationen, auch bei Bruch, können daher nicht anerkannt werden.

EN ATTENTION!

Wear protective clothing when handling glass!

Please examine the single-pane safety glass for possible transport damage such as chipped edges or corners immediately after unpacking. If damage is detected do not install the pane because a defect can lead to breakage later! Please make a damage report without delay! All glass panes are controlled with utmost care before packing. Therefore later complaints cannot be acknowledged, even in case of breakage.



FR ATTENTION ! Portez des vêtements protecteurs en manipulant du verre.

Merci de vérifier immédiatement le verre de sécurité monofeuille au déballage sur d'éventuels dommages survenus au transport, tels que chants et angles écaillés. Si toutefois un défaut a été constaté, merci d'en faire la déclaration au plus vite et ne pas monter la vitre, car ce défaut peut être, par la suite, à l'origine d'une casse! Tous les verres sont contrôlés minutieusement avant le conditionnement. Pour cette raison, aucune réclamation ultérieure, même en cas de casse, ne pourra être prise en compte.



DUETT

SHOWER & BATH

BENÖTIGTES WERKZEUG

NECESSARY TOOLS



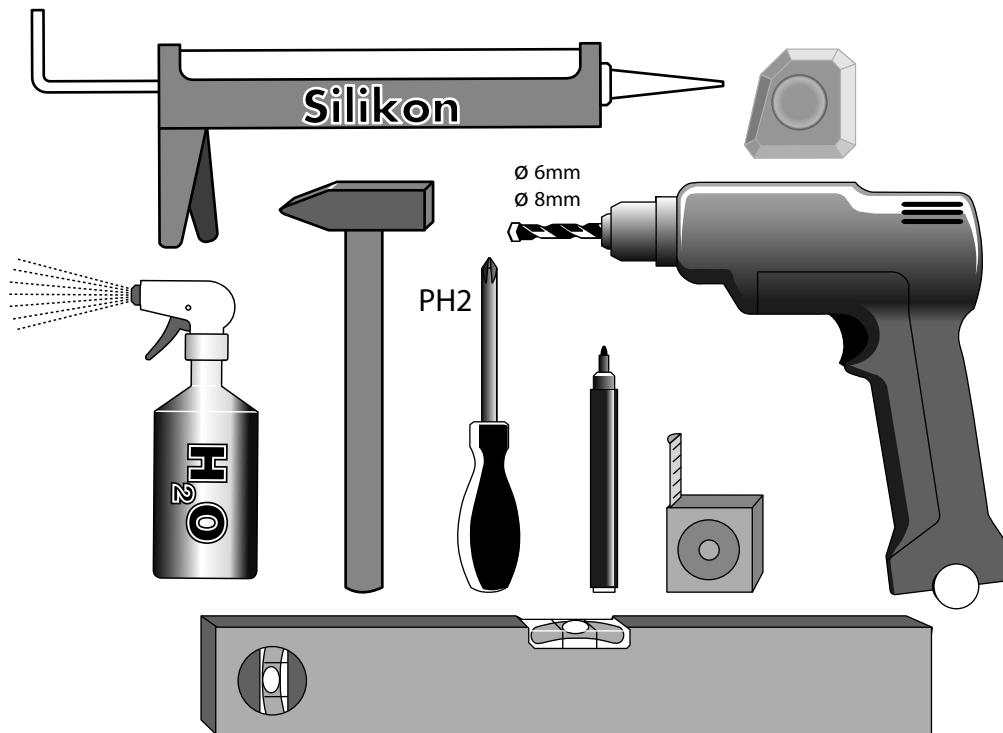



OUTILLAGE NECESSAIRE

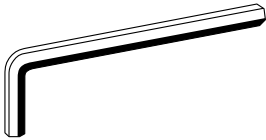
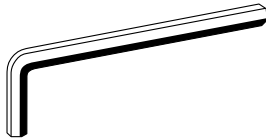
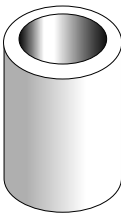
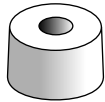
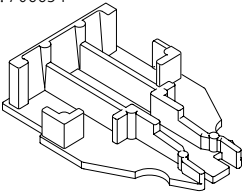
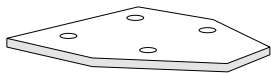

DUETT

SHOWER & BATH

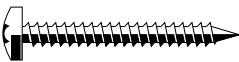
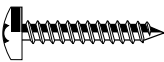
MONTAGESET	ASSEMBLY KIT	SET DE MONTAGE
-------------------	---------------------	-----------------------

<p>6x 4,8 x 60 mm MatNr: 2477</p> 	<p>10x 125A-5,3-A2 MatNr: 2430</p> 	<p>6x Ø 8mm MatNr: 24409</p> 	
<p>1x SW 4 MatNr: 18178</p> 	<p>1x SW 5 MatNr: 1880</p> 	<p>1x MatNr: 80GBD</p> 	<p>1x MatNr: 706542</p> 
<p>2x MatNr: 706634</p> 	<p>2x MatNr: 705319</p> 	<p>1x Ø 3,8mm MatNr: 18603</p> 	
<p>1x 4,2 x 38 mm MatNr: 24200</p> 	<p>3x 4,2 x 25 mm MatNr: 24193</p> 	<p>1x 4,2 x 19 mm MatNr: 24265</p> 	<p>1x Ø 6mm MatNr: 24410</p> 

DUETT

SHOWER & BATH

1

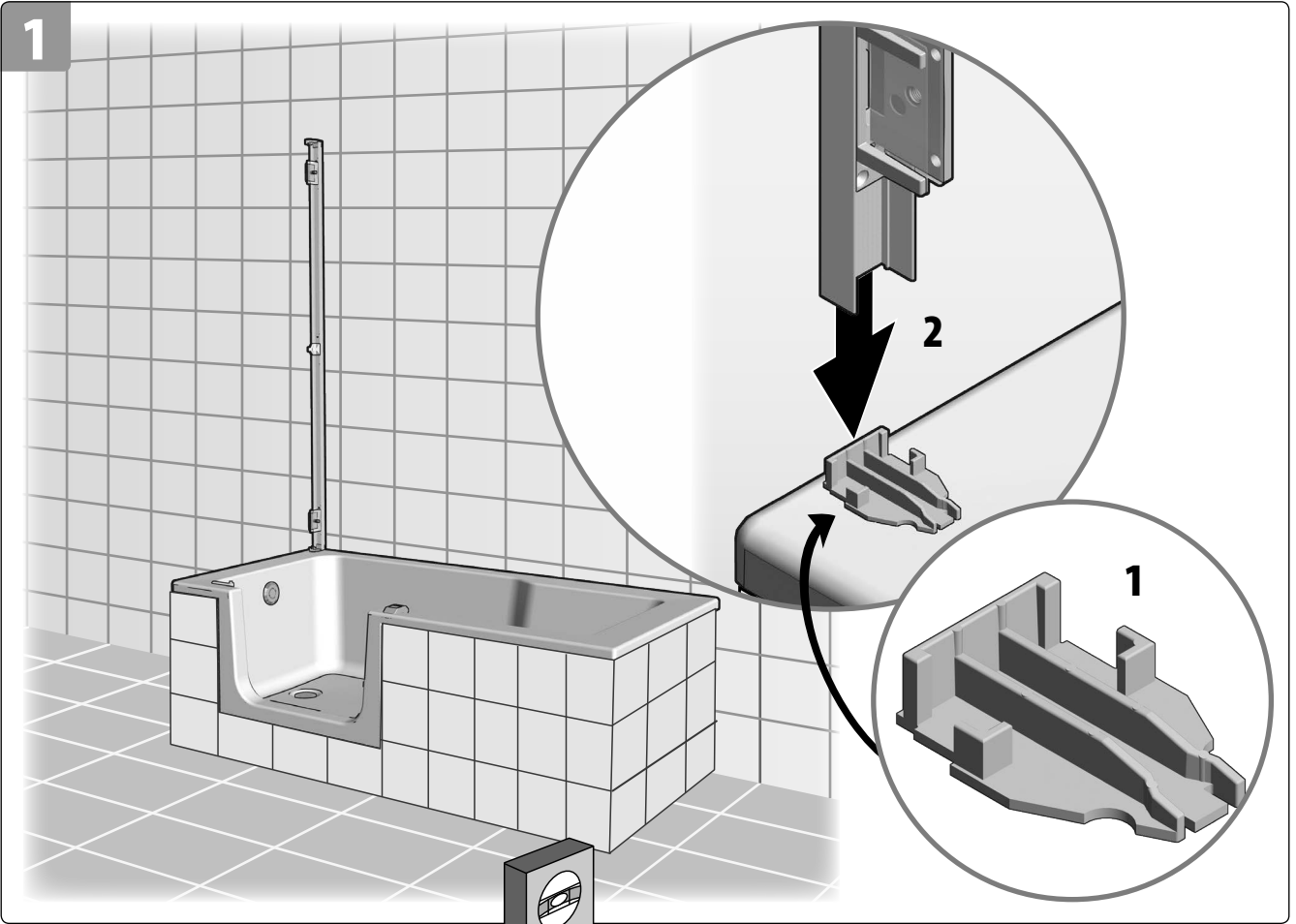

2

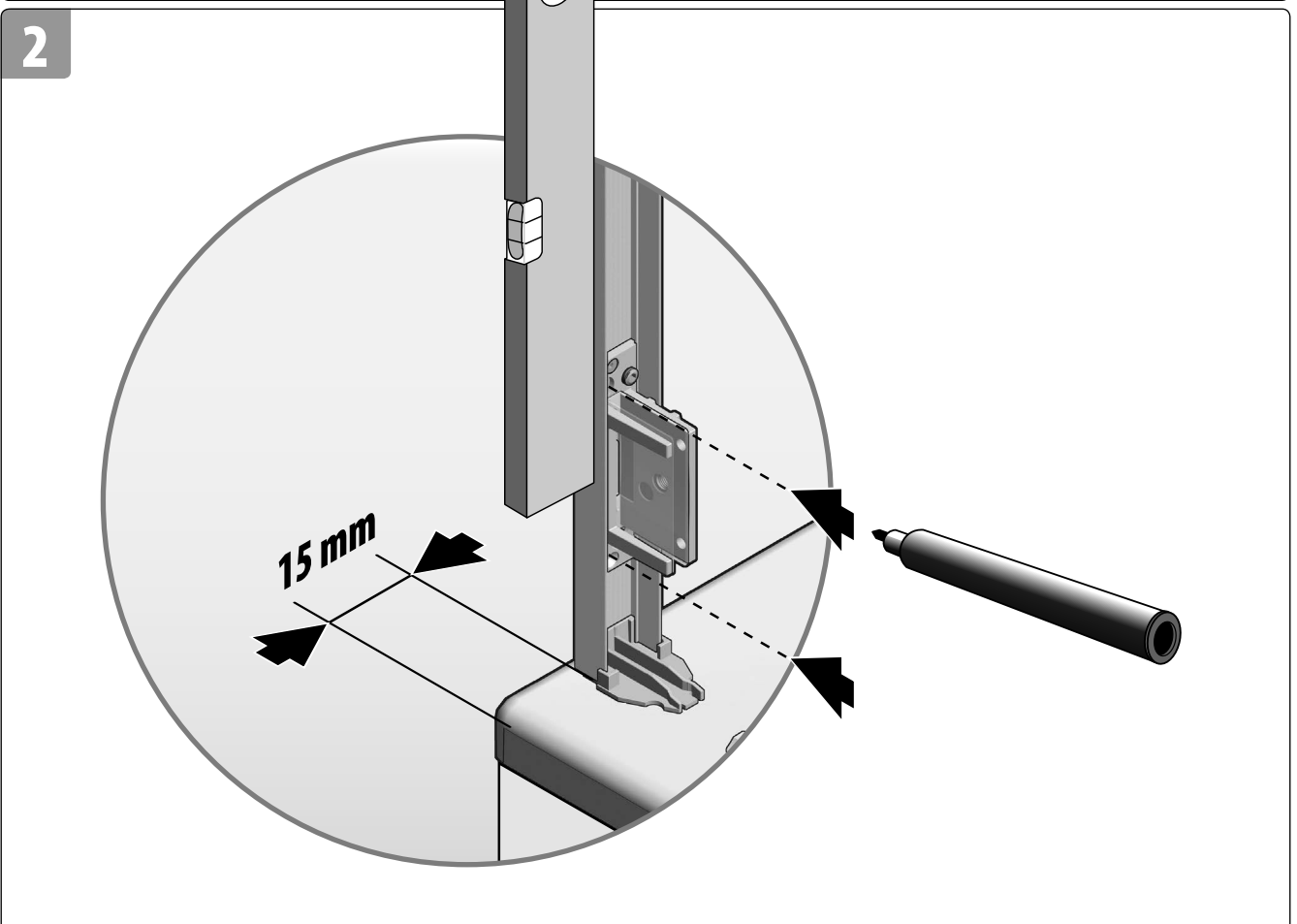

DUETT

SHOWER & BATH

3

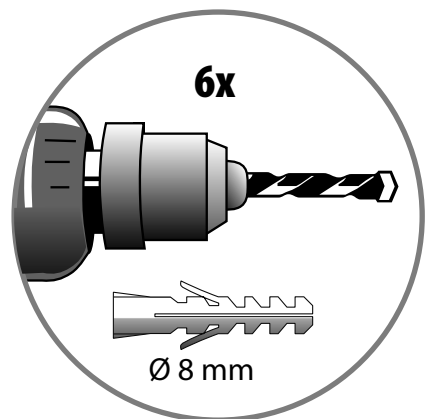
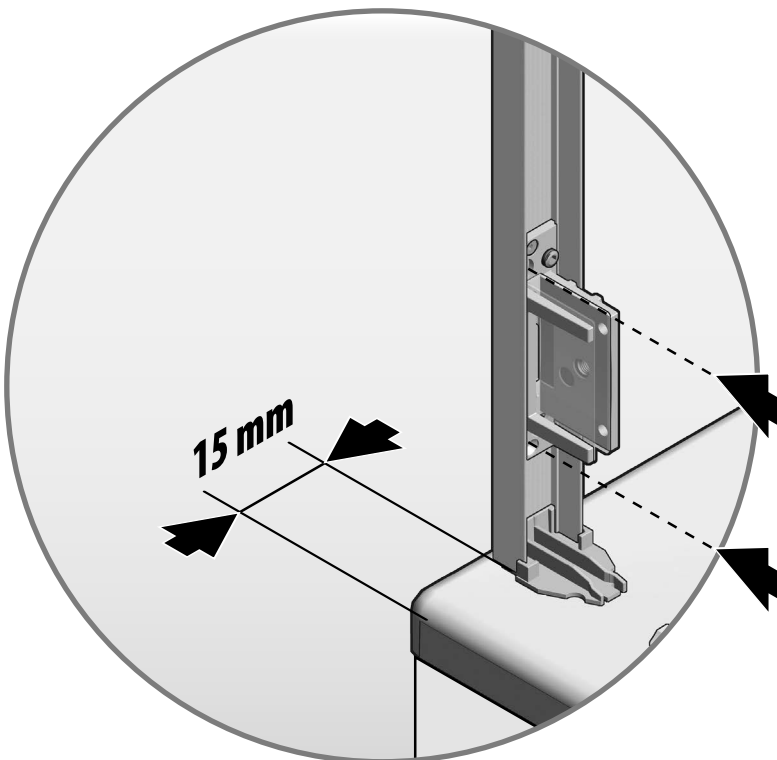
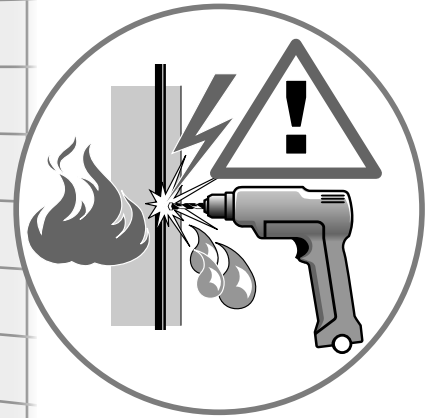
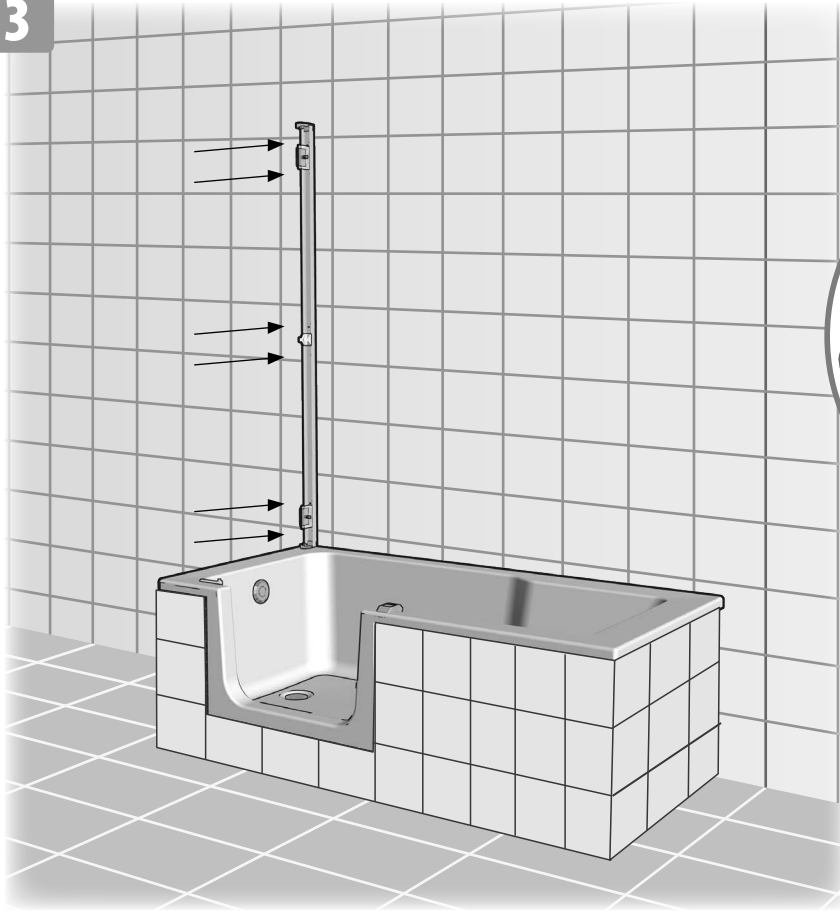

DUETT

SHOWER & BATH

4

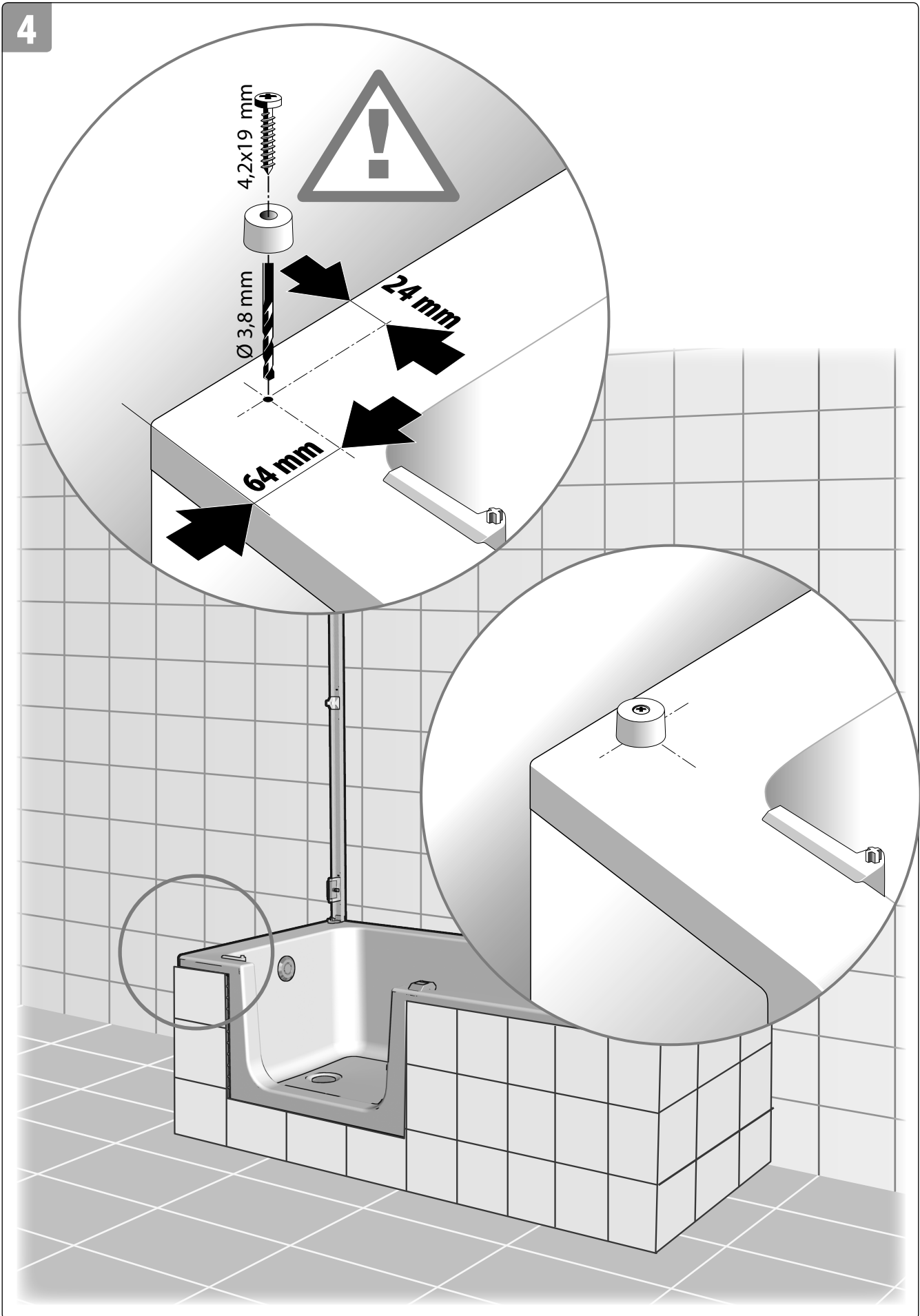

DUETT

SHOWER & BATH

5

Blick von aussen!
View from outside!
Vue de l'extérieur!
Vista dall'esterno!

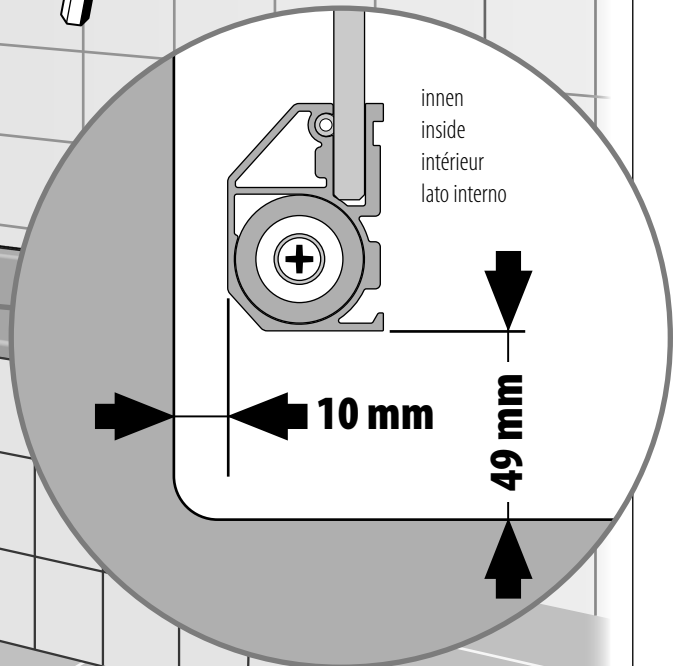
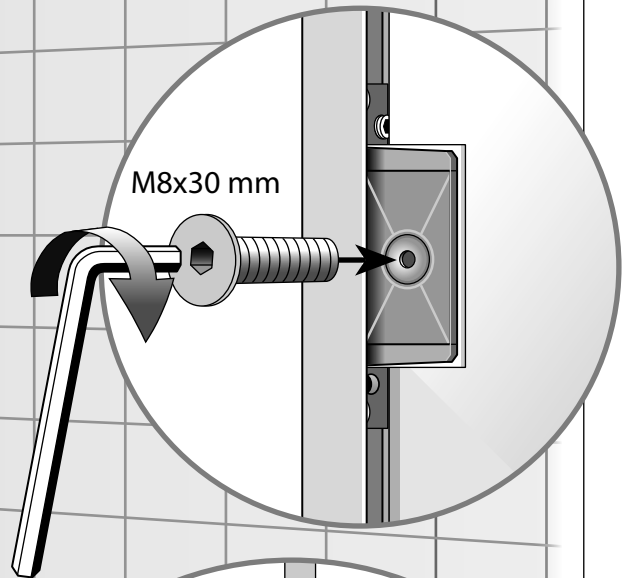
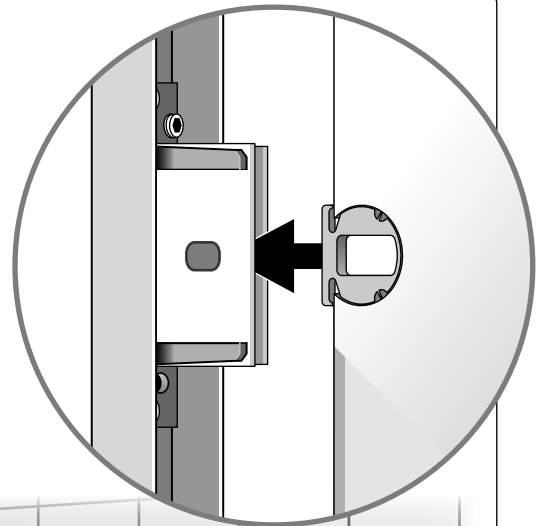

DUETT

SHOWER & BATH

6

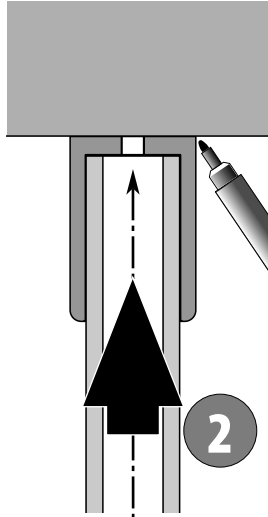

2

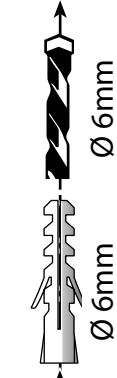

3

4,2x38 mm

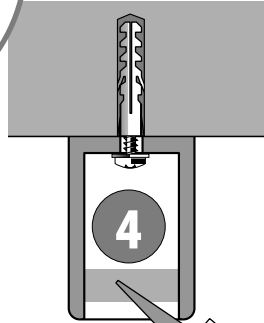

4

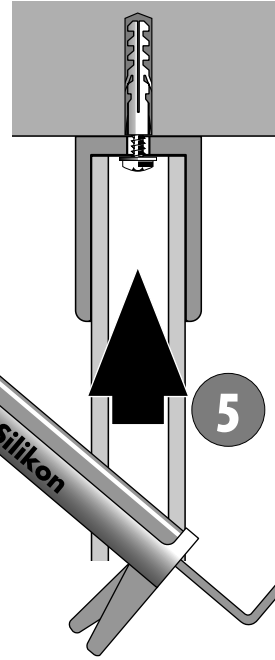

5

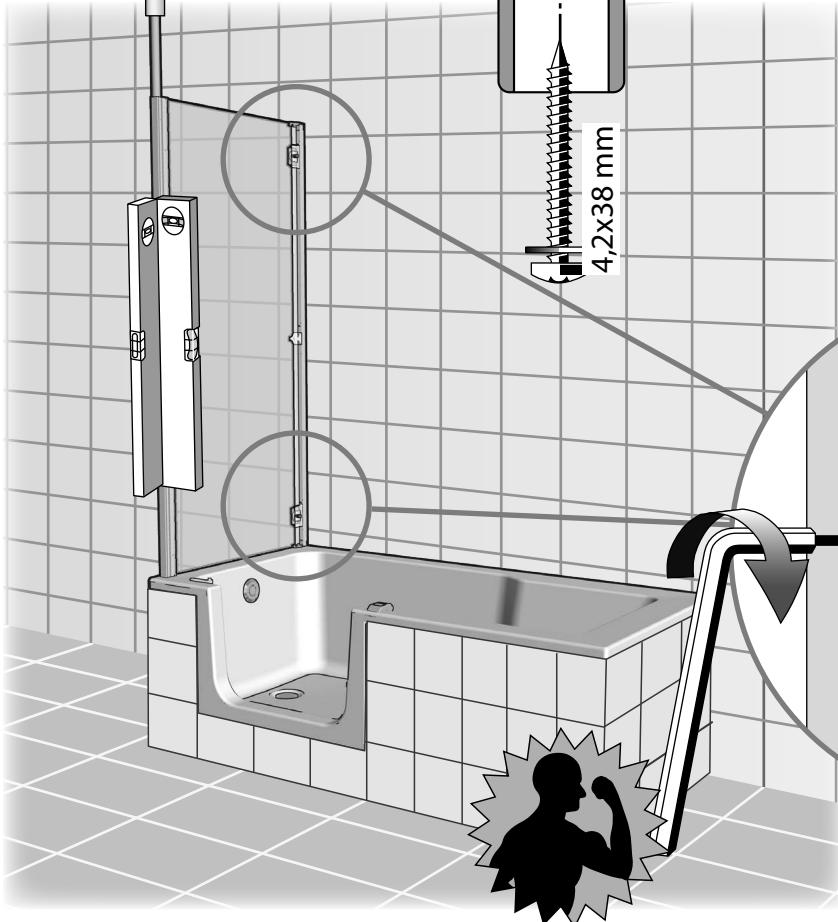

1

Blick von aussen!
View from outside!
Vue de l'exterieur!
Vista dall'esterno!

DUETT

SHOWER & BATH

7

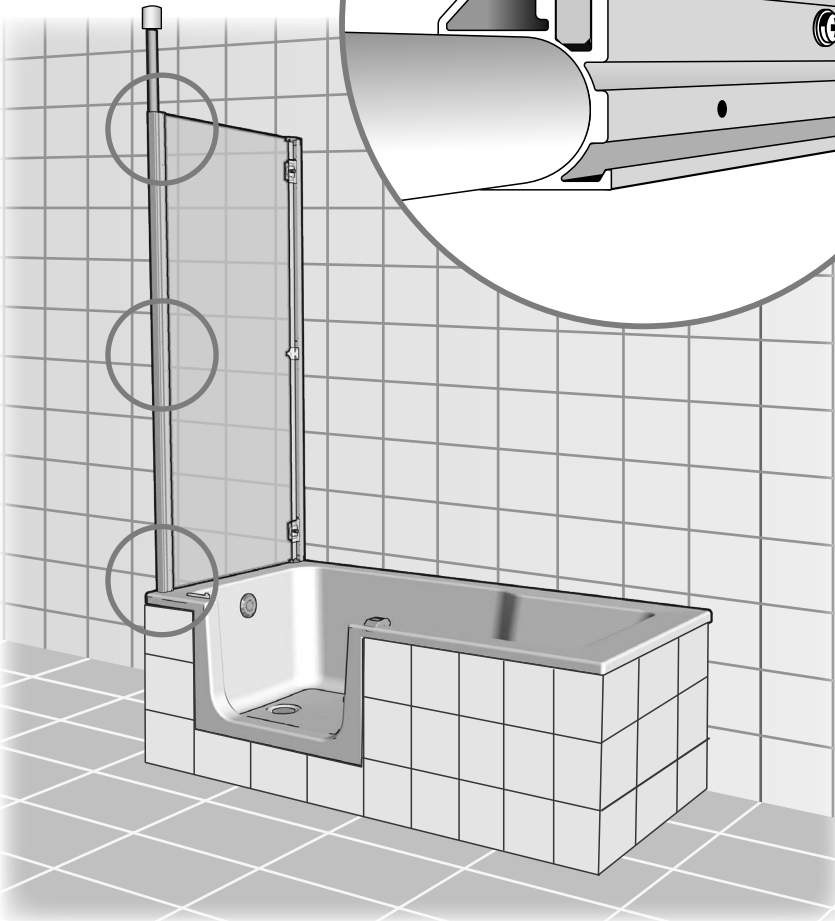
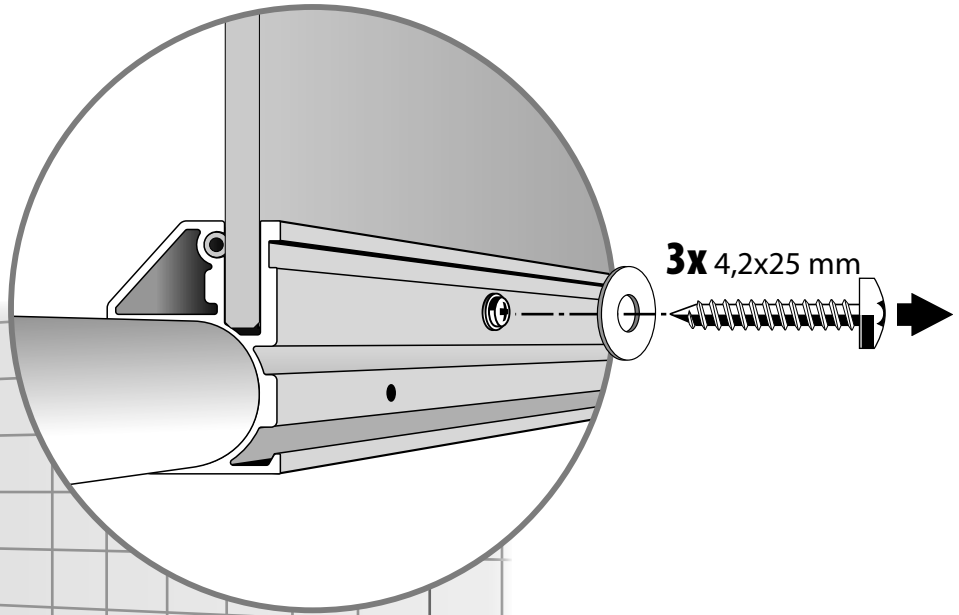
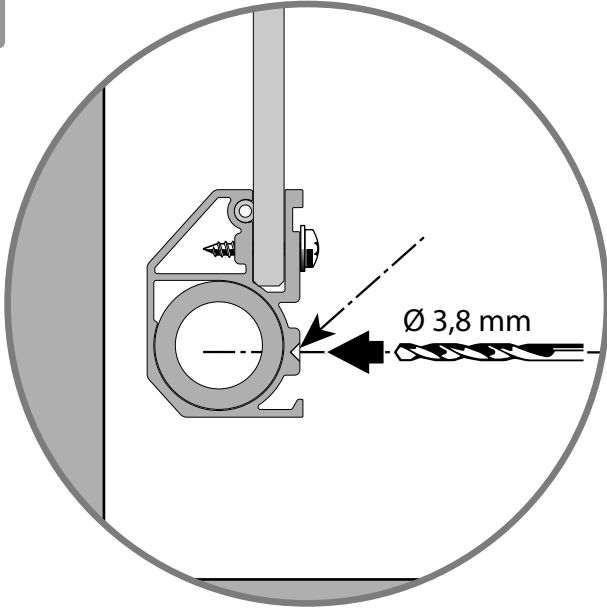

DUETT

SHOWER & BATH

8

6x 4,2x25 mm

innen
inside
intérieur
lato interno

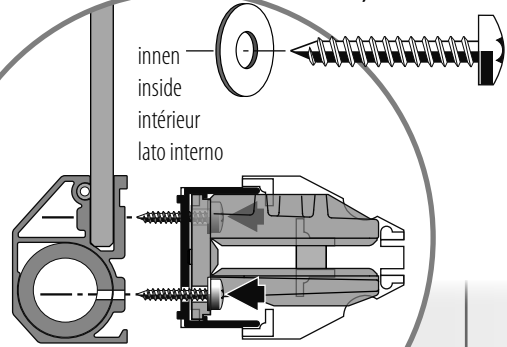

innen
inside
intérieur
lato interno

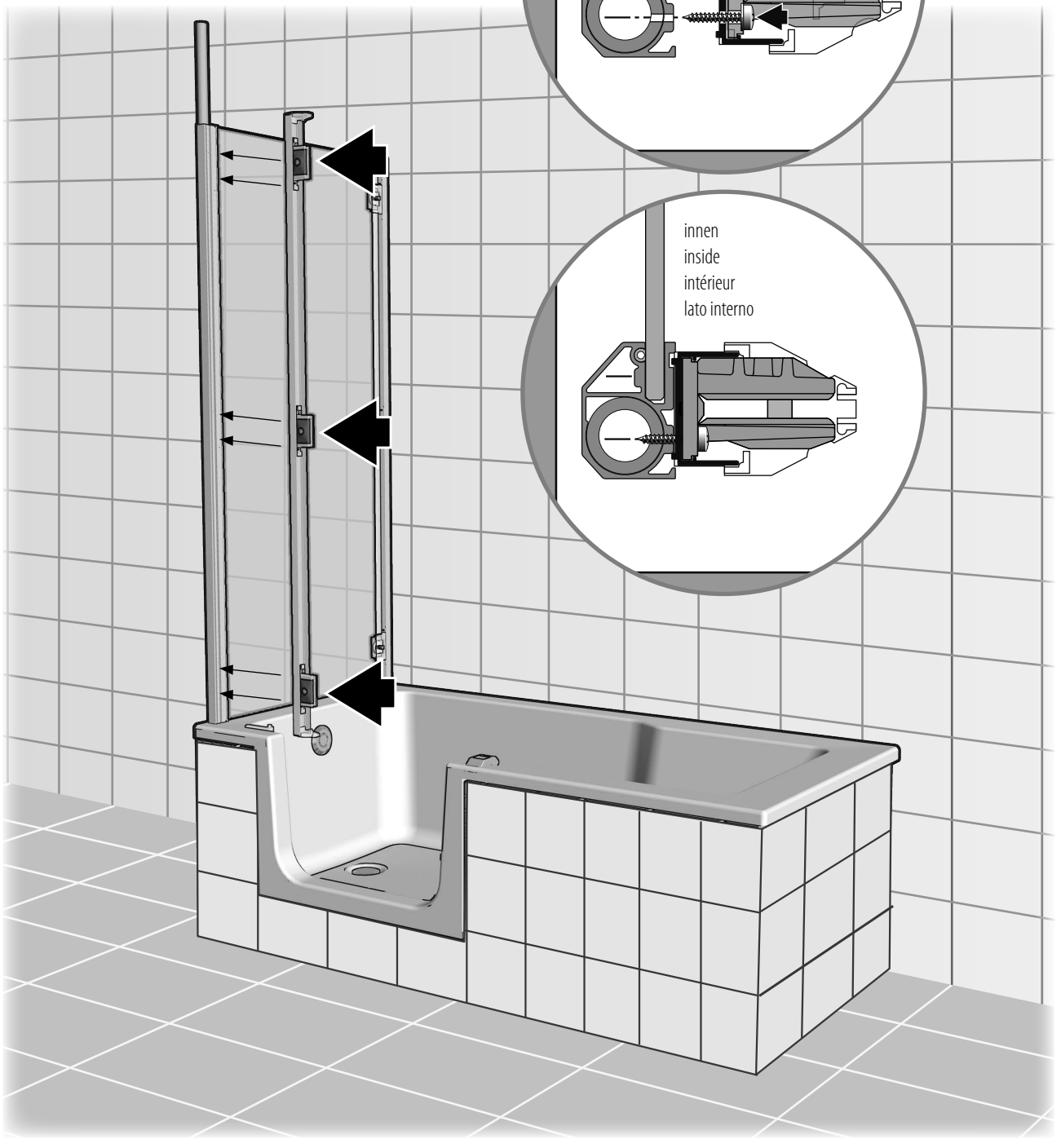
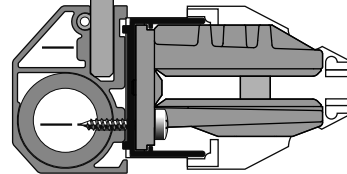

DUETT

SHOWER & BATH

9

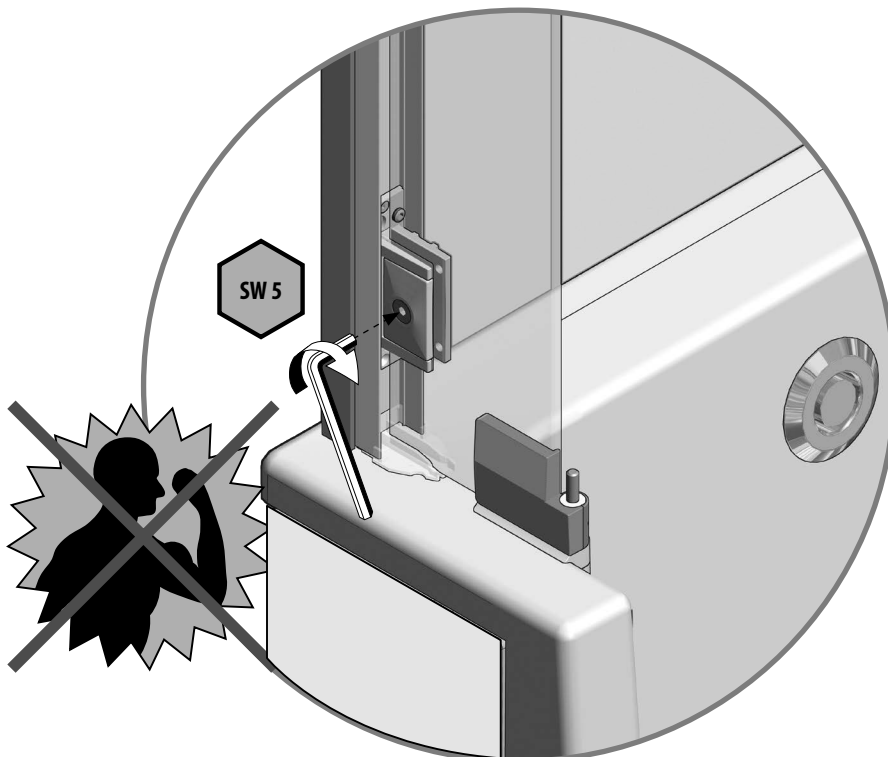
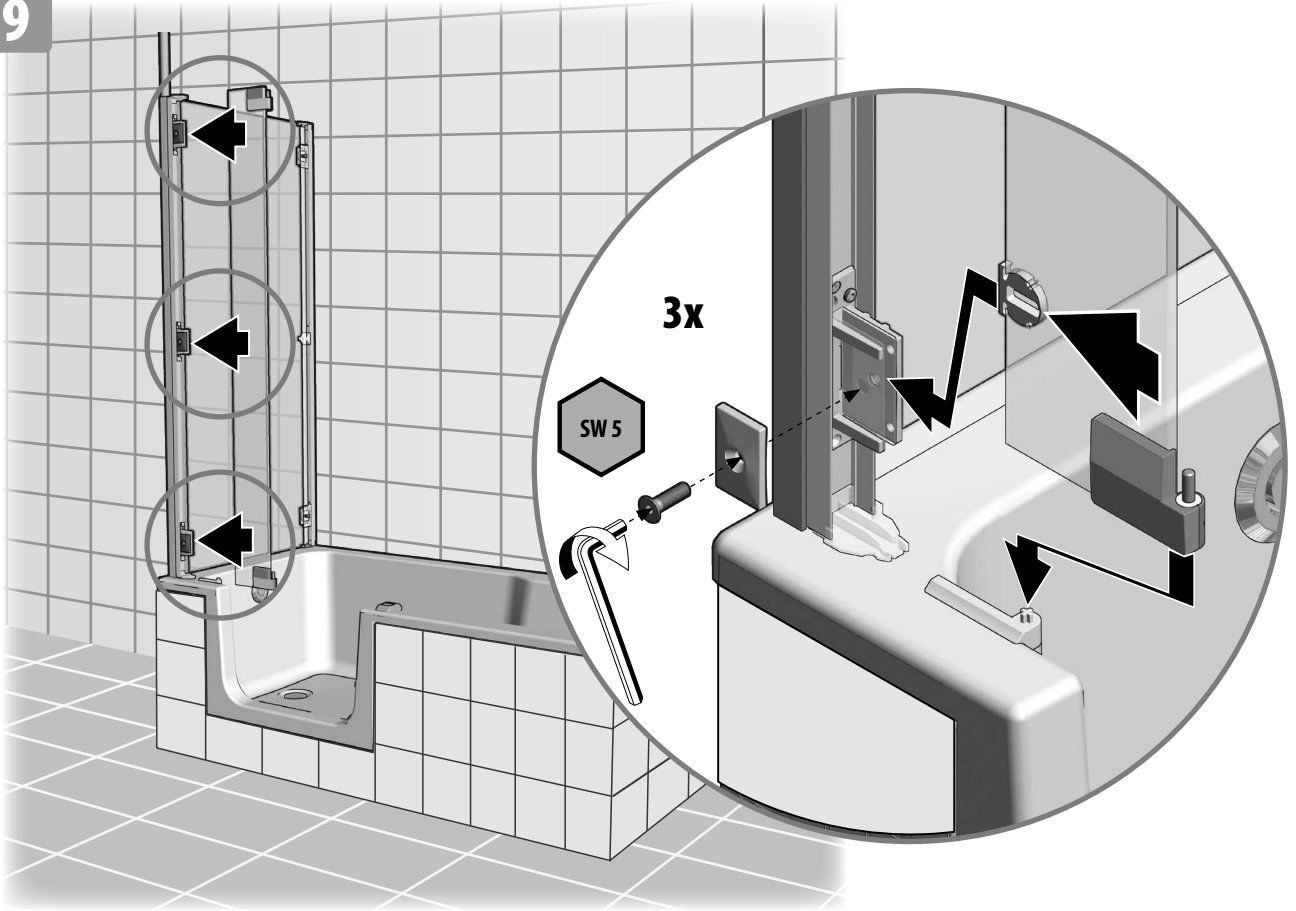

DUETT

SHOWER & BATH

10

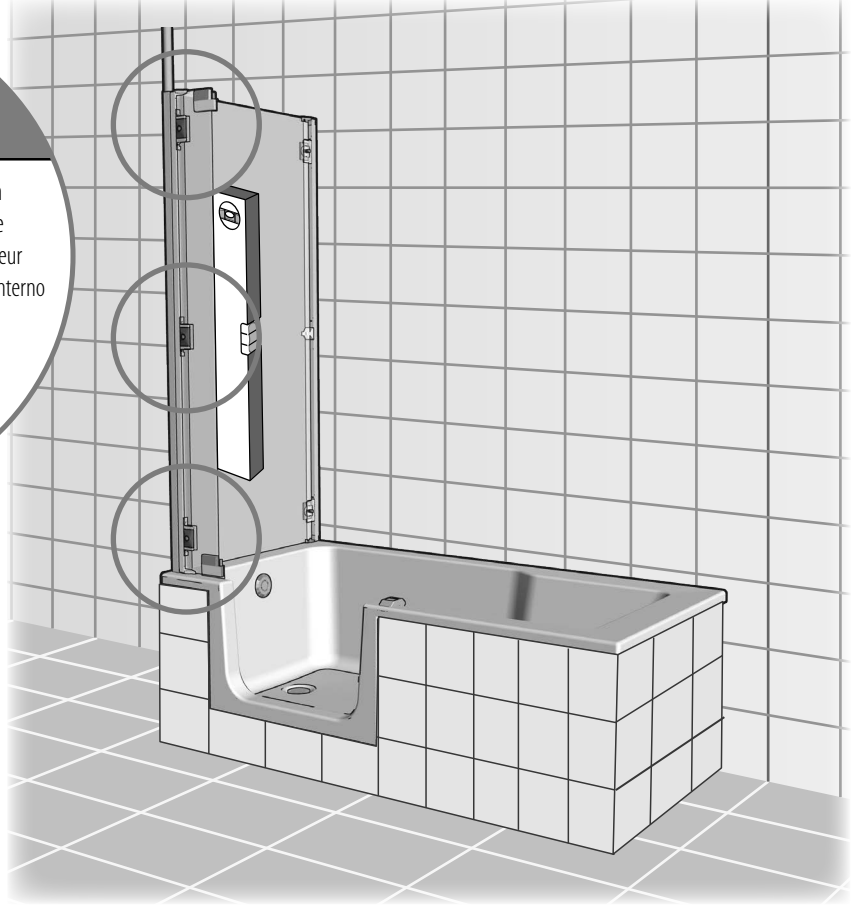
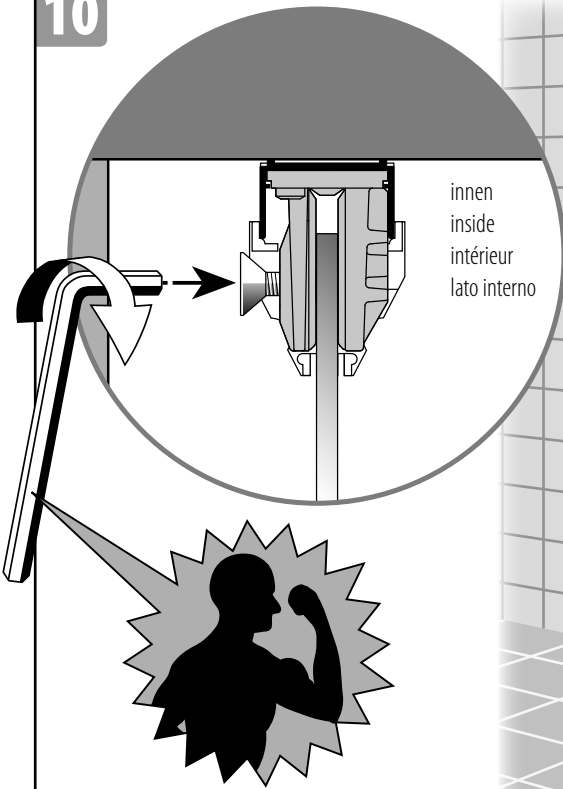

11

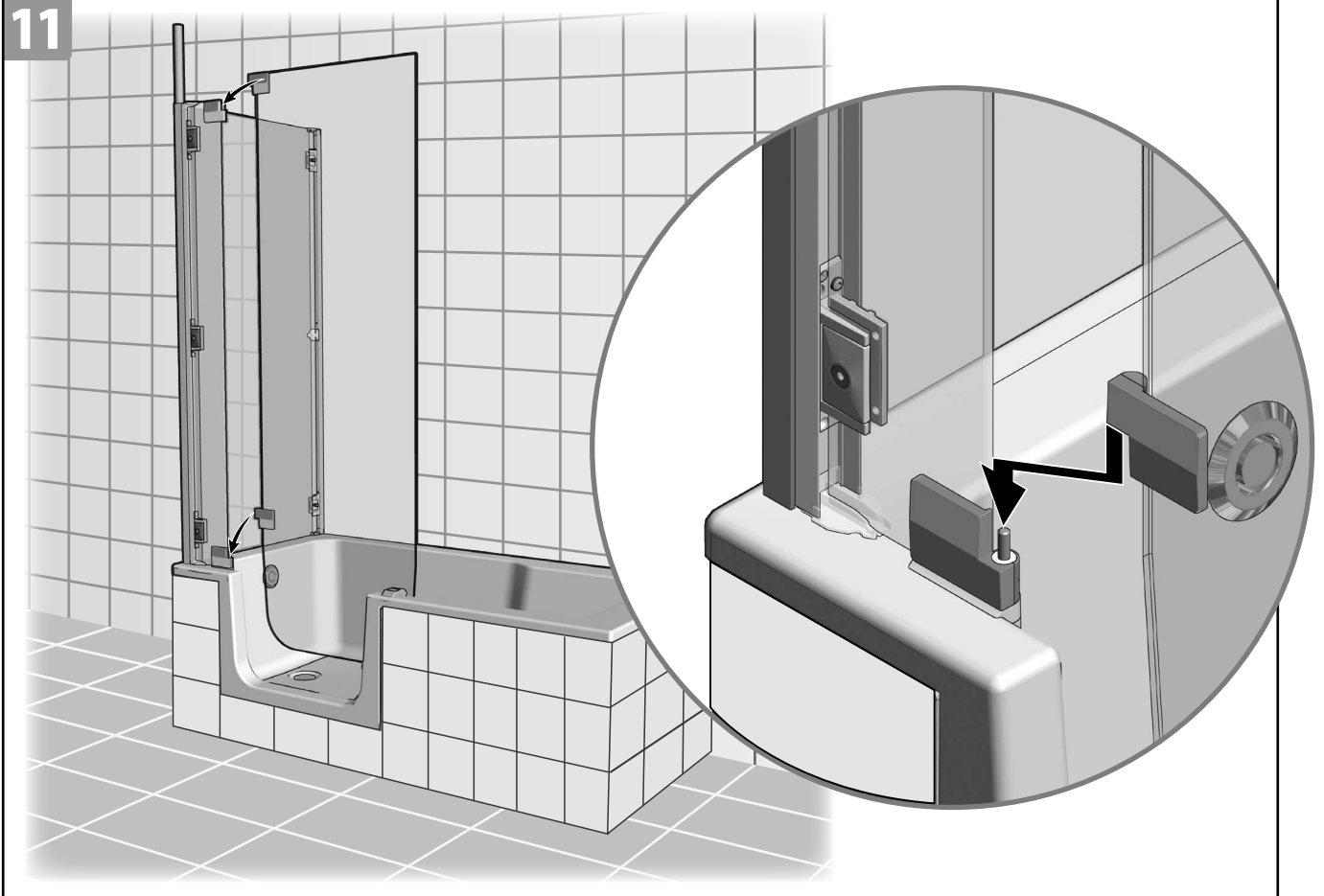

DUETT

SHOWER & BATH

12

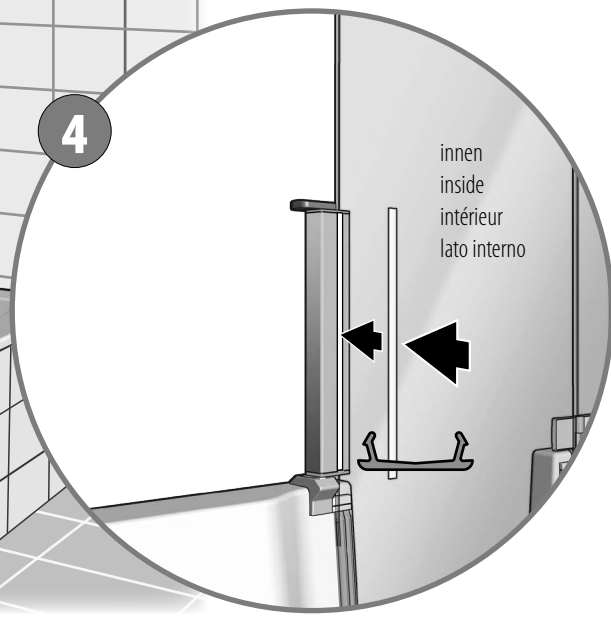
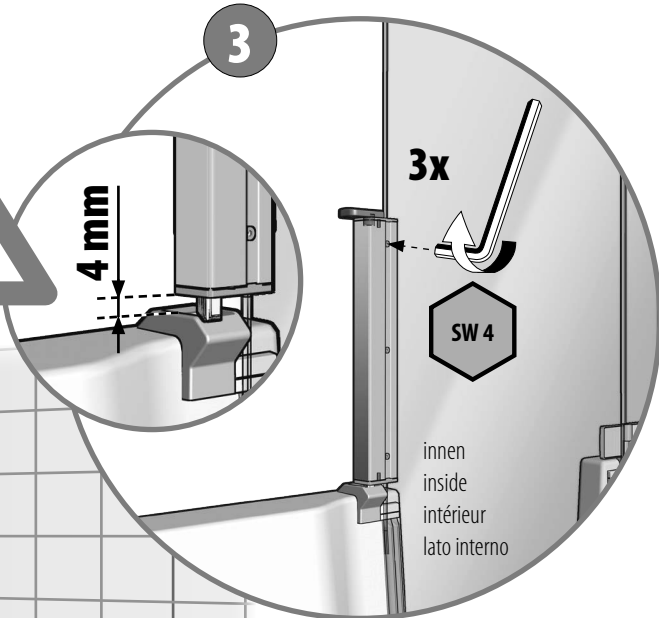
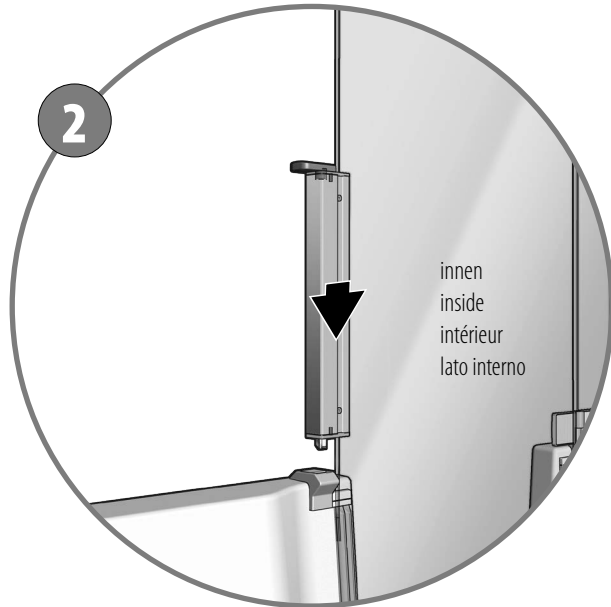
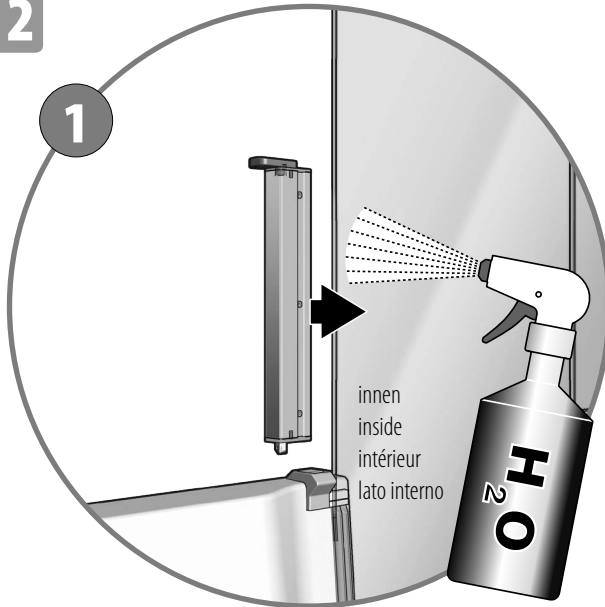

DUETT

SHOWER & BATH

13

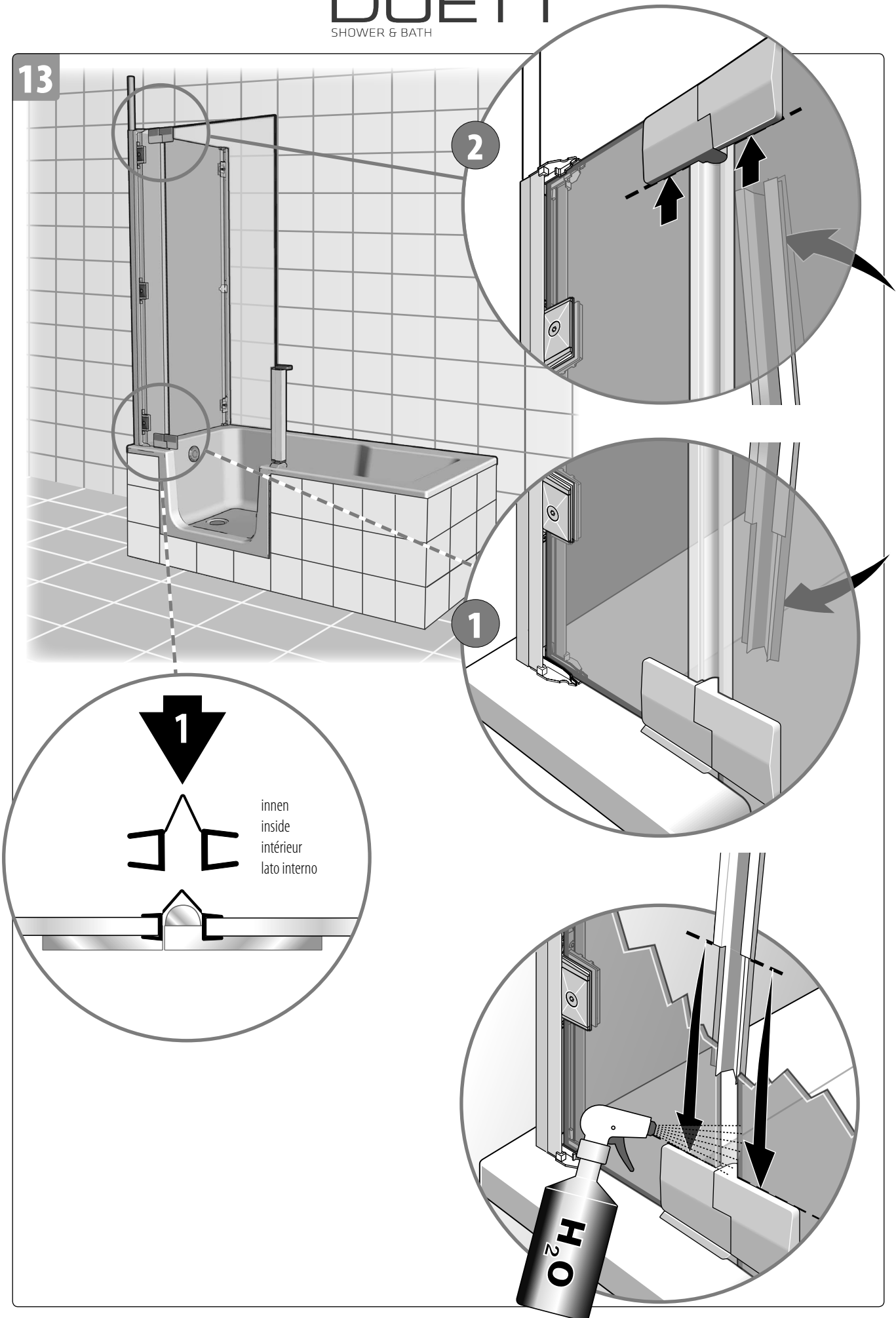

innen
inside
intérieur
lato interno

H₂O

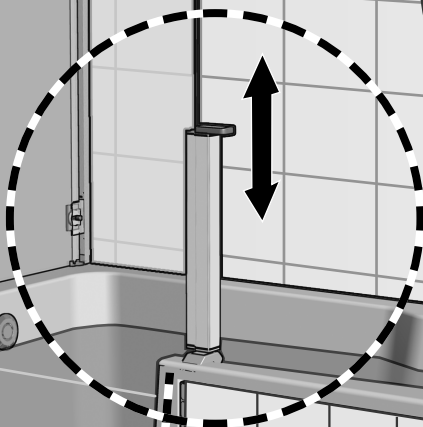
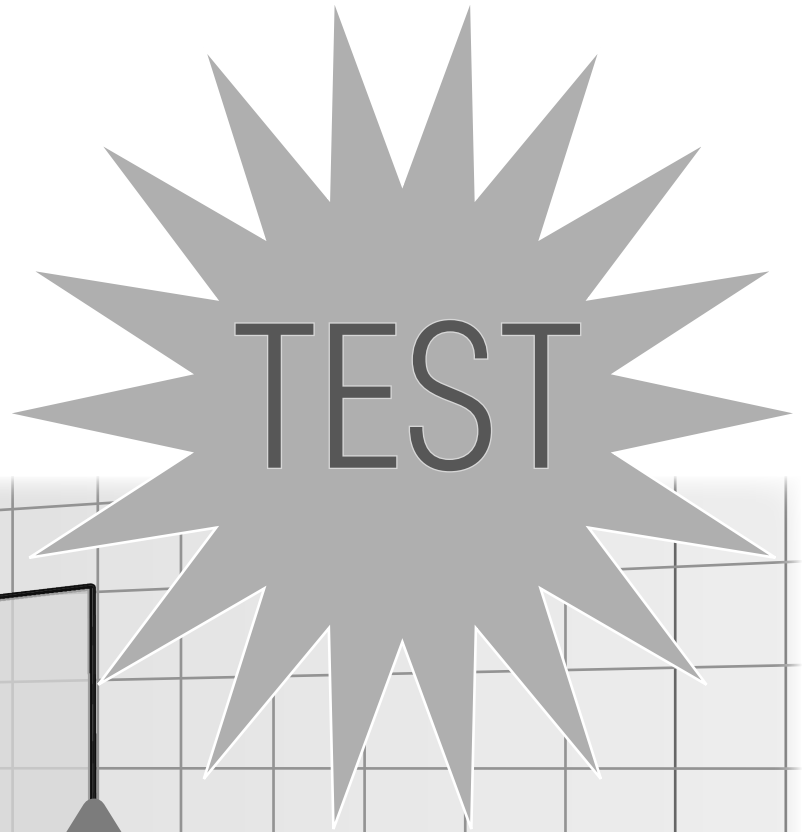

DUETT

SHOWER & BATH

15

1

innen
inside
intérieur
lato interno

2

3

innen
inside
intérieur
lato interno

4

innen
inside
intérieur
lato interno

Silikon

Silikon

DUETT

SHOWER & BATH

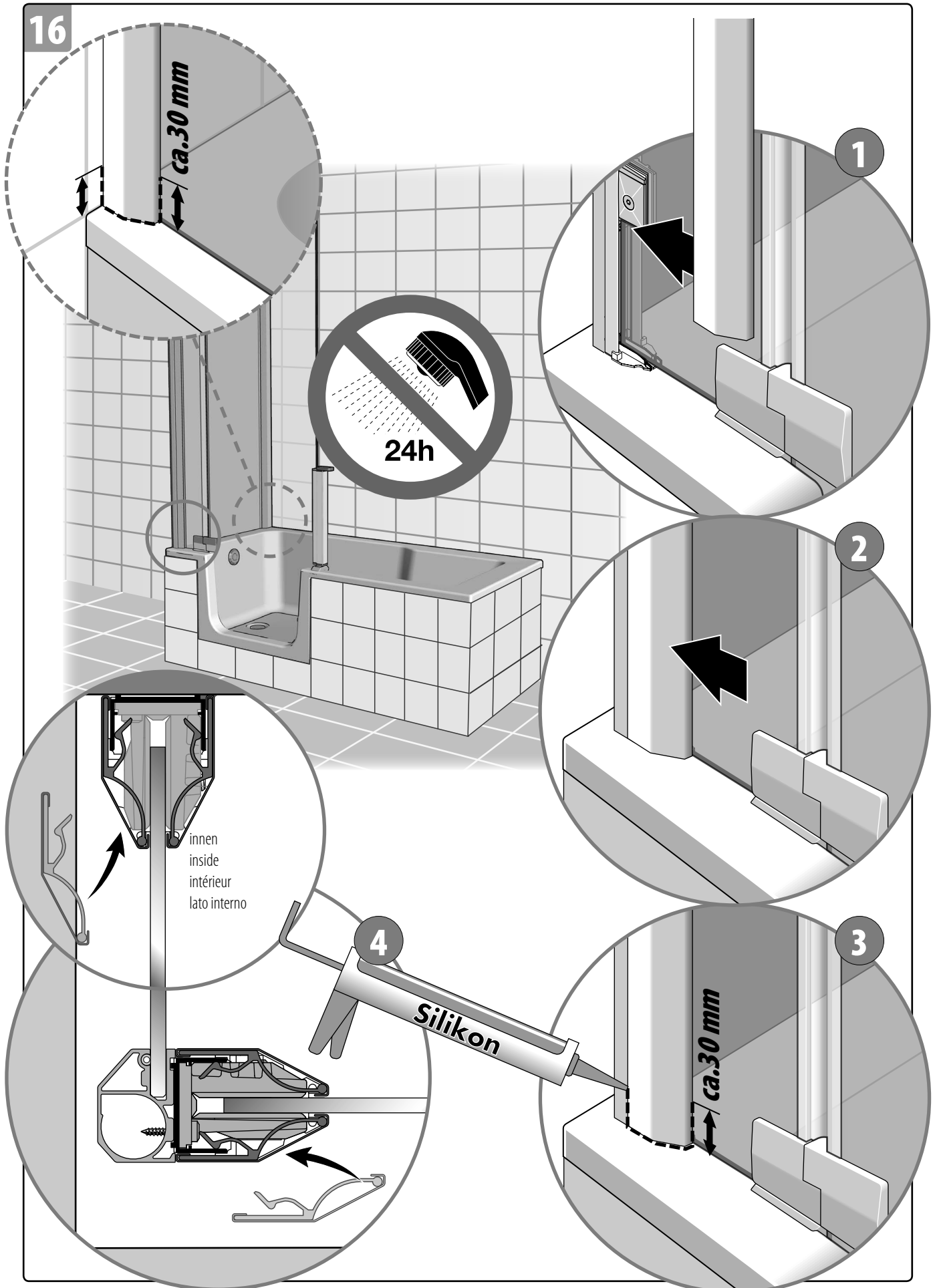

DUETT

SHOWER & BATH

ERSATZTEILE

SPARE PARTS

PIÈCES DÉTACHÉES

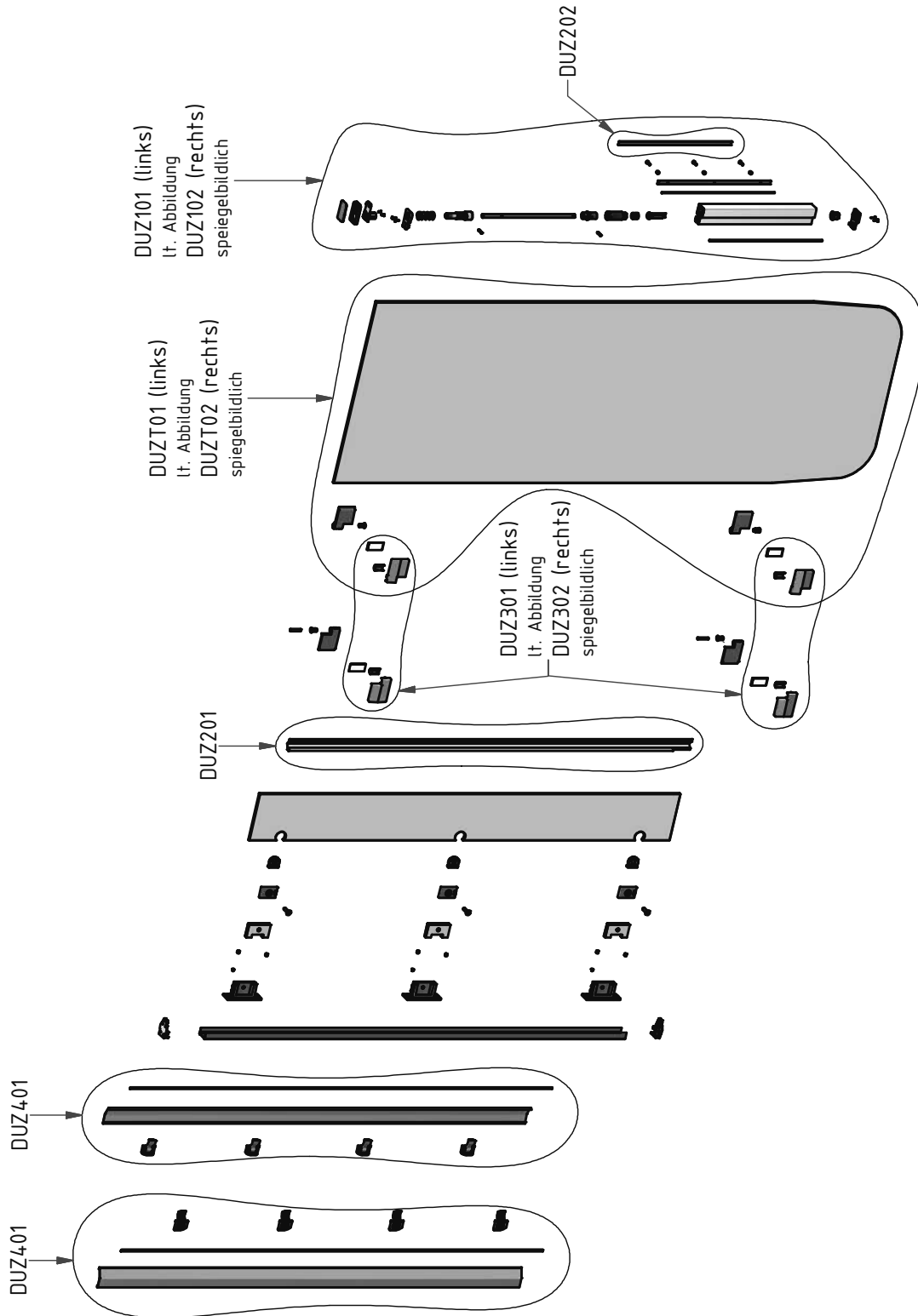

MA_DUBW_Duett_TürSW_11915_09_15